

Feature

- Modular octagonal linear lighting offer infinite possibilities.
- High quality, energy-efficient LED Lighting for environmental protection.
- For offices, conference rooms, supermarkets, home lighting, airports, museums, libraries, corridors, cinemas, hotels, etc.



Modular



DIY Splicing



Customizability



Easy Maintenance



Scalability



Flexibility



Shrapnel-type Wiring

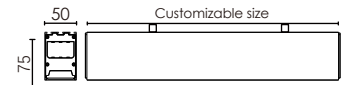
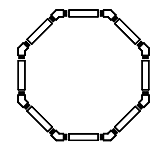

Luminaire parameters

Model	HL-PB5075A-E81
Size	1200*1108mm
Nominal Power	100W
Lm	10000lm±10% (@4000K)
Beam Angle	110°-120°
Input Voltage	AC200-240V
CCT	2700-6500K
CRI	>80
Protection Grade	IP20
Certification	CE, ROHS
Warranty	3 years

Units:mm

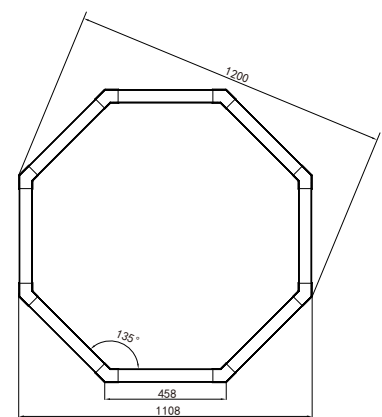

Installation Accessories



module 1



module 2

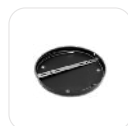

Accessory

Installation

Step 1: Assembly product

Please assemble the modules corresponding to the correct angles.

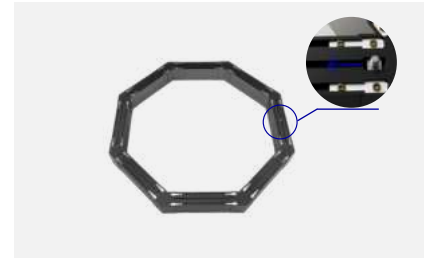
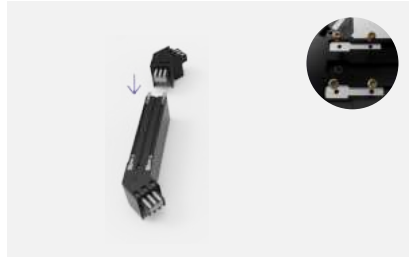
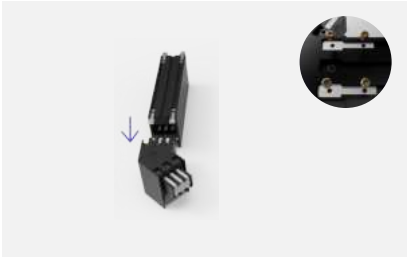

Step 2: Install

Please make sure that the place of installation could stand 10 times the weight of itself before installing in a place where is no vibration, no swing, and no fire risk.

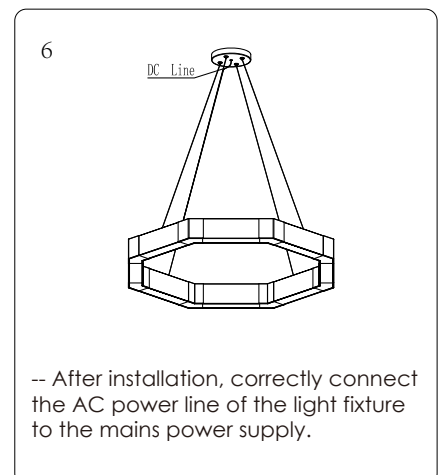
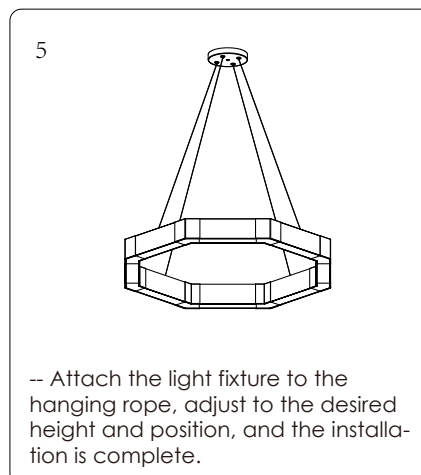
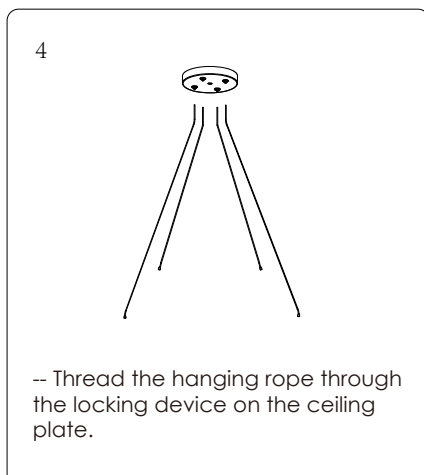
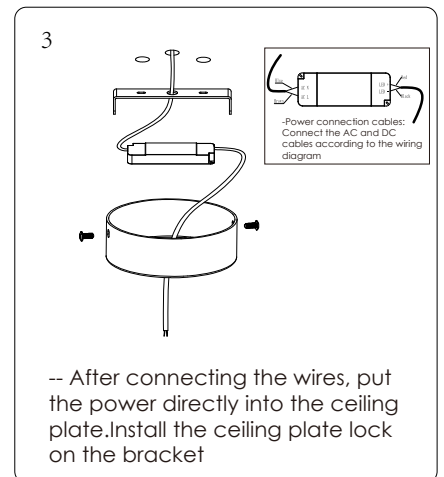
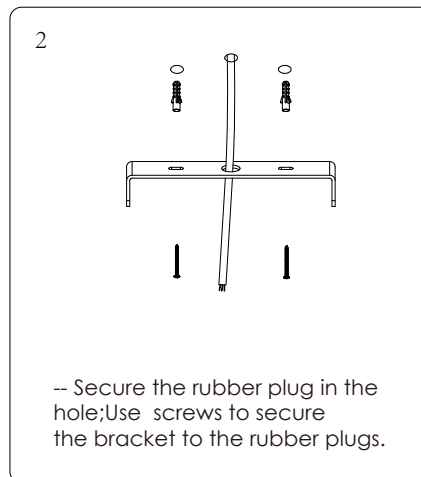
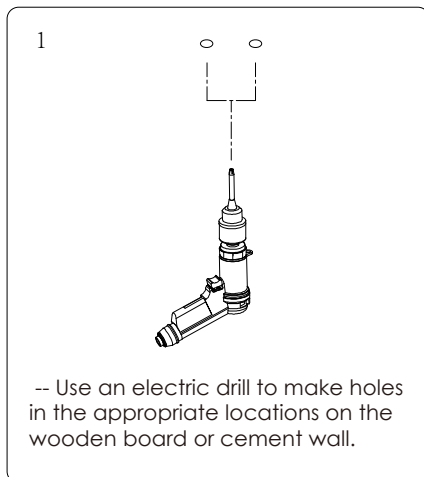

Packing

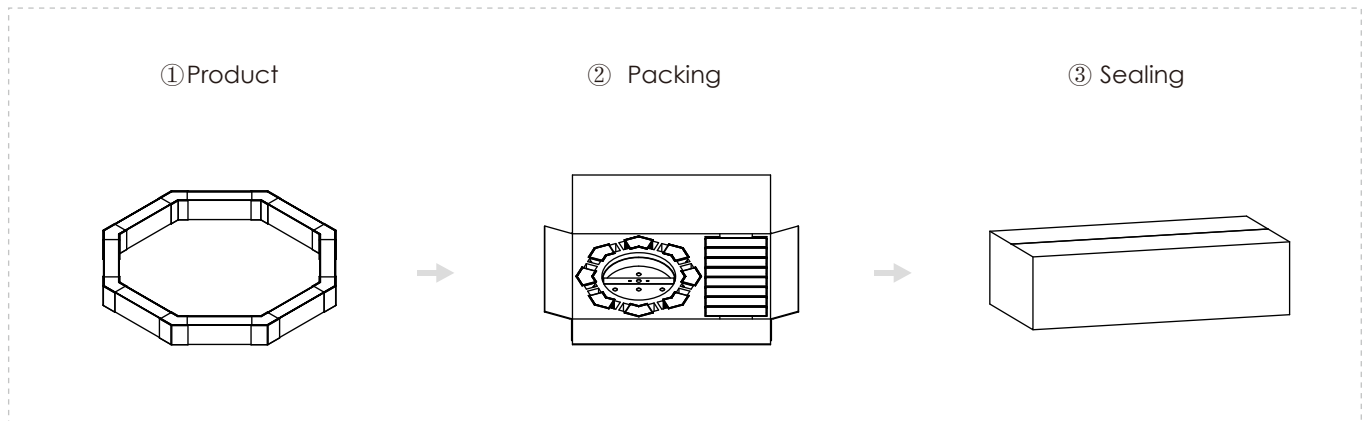

Model	HL-PB5075A-E81	Carton box	860*480*440mm
Inner box	840*460*100mm	QTY/Carton	4 PCS
NW	7.3kg/PCS	GW	8.2kg/PCS

USER INSTRUCTIONS

- 1.The installation of the unit must be done by a qualified electrician.
- 2.The unit must be earthed in case an earth connecting point exists.
- 3.Ensure that the mains is switched off during servicing.
- 4.Do not use bulb(s) bigger than the indicated on units name-plate or packaging.
- 5.Ensure that after the installation,the unit is properly fixed and the cable clamps (if exist)are well tightened.
- 6.Manufacturer will not accept liability for injury or damage resulting from incorrect use or installation.