

UGR<16

Feature

- Professional appearance design, simple and elegant.
- High quality, energy-efficient LED Lighting for environmental protection.
- External power supply, no flicker.
- Optional cover for the lamp (Reflector cup / PC cover).
- Professional anti-glare grille reflector cup, anti-glare value UGR<16, light comfort, eye protection.
- Application: offices, conference rooms, supermarkets, schools, home lighting and so on.

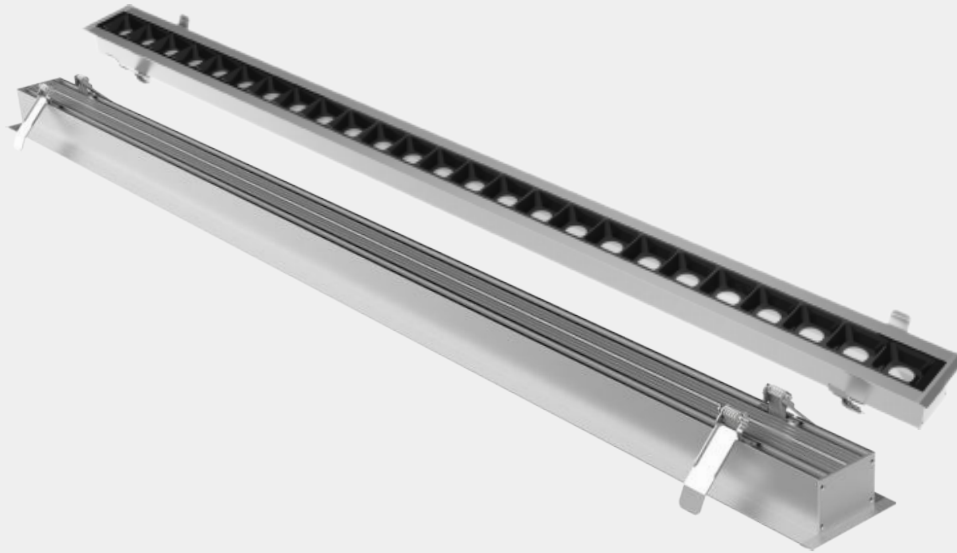
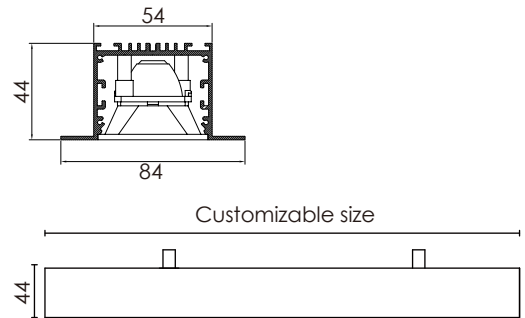
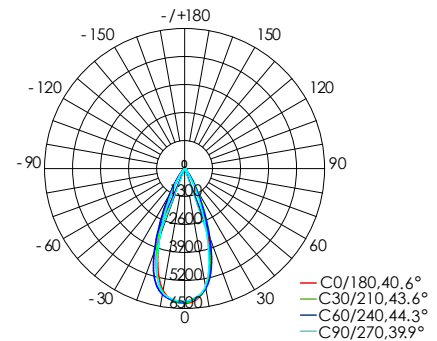

Luminaire parameters	
Size	L1200*W84*H44mm
Lm	3400lm / 4500lm
Input Voltage	AC100-240V
Beam Angle	15°/30°/45°
Nominal Power	50W
CCT	2700-6500k
CRI	>80
Protection Grade	IP40
Certification	CE, RoHS
Warranty	3 years



Height	Eavg,Emax	Diameter
1m	4523, 6250lx	72.16cm
2m	1131, 15631lx	144.31cm
3m	502.6, 694051lx	216.47cm
4m	282.7, 390.6lx	288.62cm
5m	180.9, 250.01lx	360.78cm

Installation Accessories

Note: The curve is the illumination area and the average illuminance of the luminaire under different projection distances.

Installation

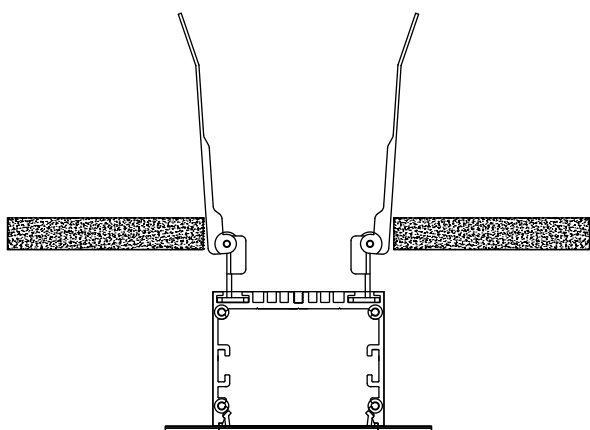

Step ①

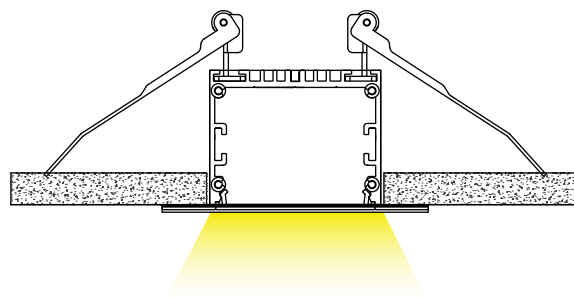

Step ②

Packing

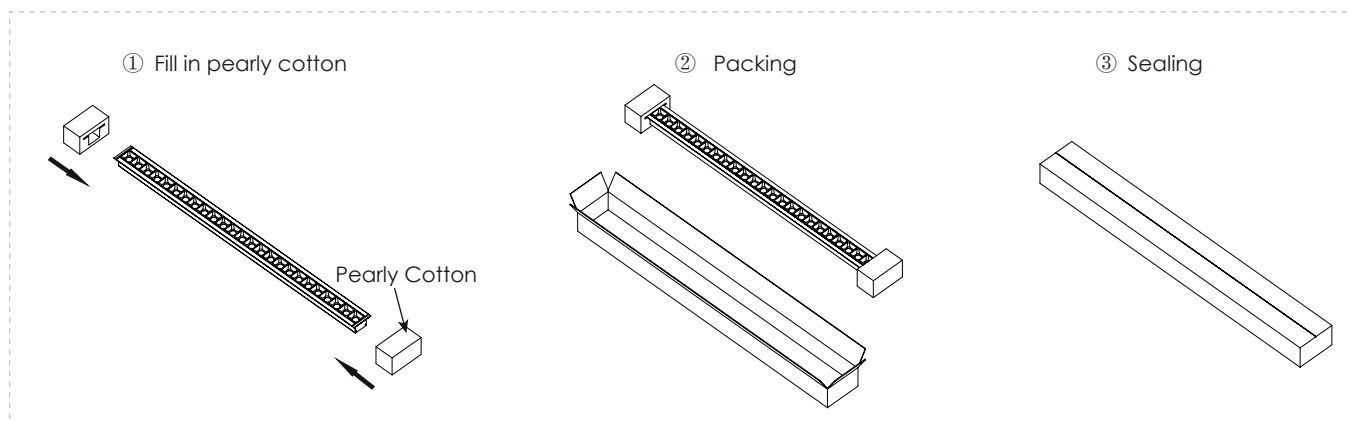

Model	HL-TA047-L12	Carton box	1263*474*201mm
Inner box	1248*153*93mm	QTY/Carton	6 PCS

Notices

- 1.The power supply must be turned off before installation.
- 2.Make sure the product is mounted under the surface of the object to be installed, and finally turn on the power to light up.
- 3.This product is for indoor use only.
- 4.This product is warranted for 3 years and problems occur within 3 years (except for human factors and accidental factors), free maintenance.
- 5.The product is not responsible for damage caused by accidental factors or improper use.