



Model: HL-G3035L



HL-G3035L-A-D01

HL-G3035L-B-D01

SIZE

Unit: mm Color: 

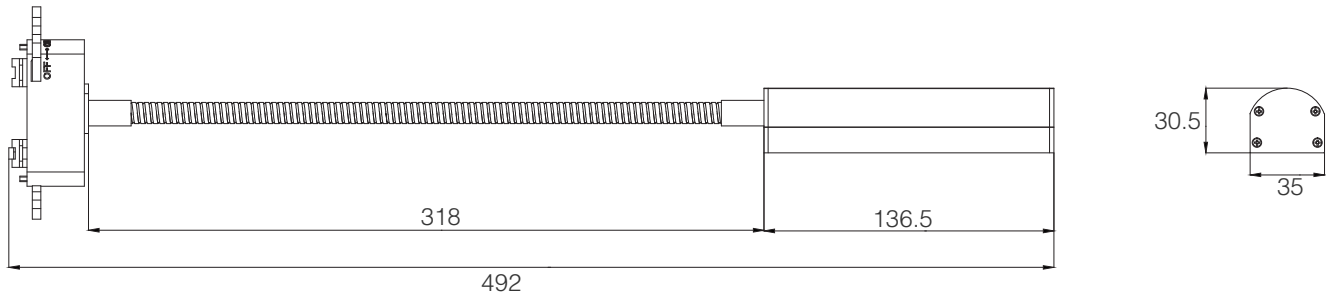

Feature

- The integrated design of hose, lamp body and guide rail joint is adopted, and the appearance design is simple and compact;
- Using SMD LED light source, low power consumption, long life, good heat dissipation performance, energy saving and environmental protection;
- It adopts built-in low-voltage constant current power supply, which is safe and reliable to use;
- Using PC material cover, high lighting transmittance, strong weather resistance, high temperature resistance, corrosion resistance, strong impact resistance;
- Optical prism design, anti-glare value $UGR < 19$, soft and comfortable light, protect eyes;
- The main material of the lamp is 6063-T5 aluminum, which has good heat dissipation performance, long service life and is more environmentally friendly;
- The luminous angle of the lamp body can be adjusted freely through the hose;

Accessories



Rail connector 1



Rail connector 2

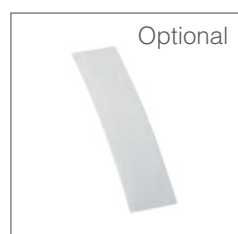

Opal prism diffuser

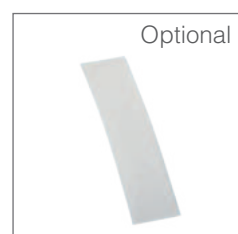

Semi-clear prism diffuser

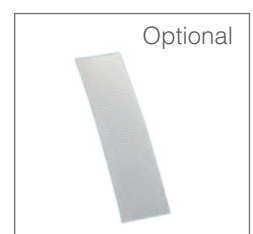

Clear prism diffuser

PARAMETERS

Model	HL-G3035L-A-D01			HL-G3035L-B-D01		
Cover	Opal prism diffuser	Semi-clear prism diffuser	Clear prism diffuser	Opal prism diffuser	Semi-clear prism diffuser	Clear prism diffuser
Nominal Power	5W			5W		
LM	425lm	450lm	450lm	425lm	450lm	450lm
Beam Angle	110°			110°		
Length(L*W*H)	L492*W35*H30.5mm					
Dimming	NO					
Rated Voltage	DC12-24V					
CRI	>70					
CCT	2700-6500k					
Warranty	3 years					
N.W	0.26KG			0.26KG		
Working Temperature	-20~+50 °C					

INSTRUCTIONS

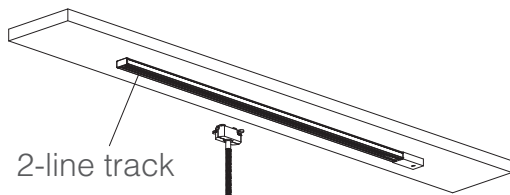

Step 1: Plug the light into the track.

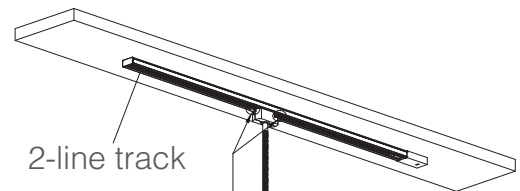

Step 2: Tighten the switch

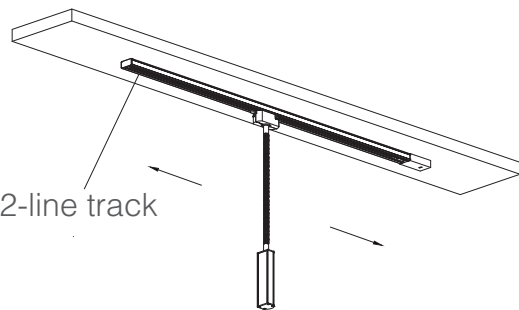

Step 3: Adjust the position and angle of the track light.

ROTATION DIAGRAM

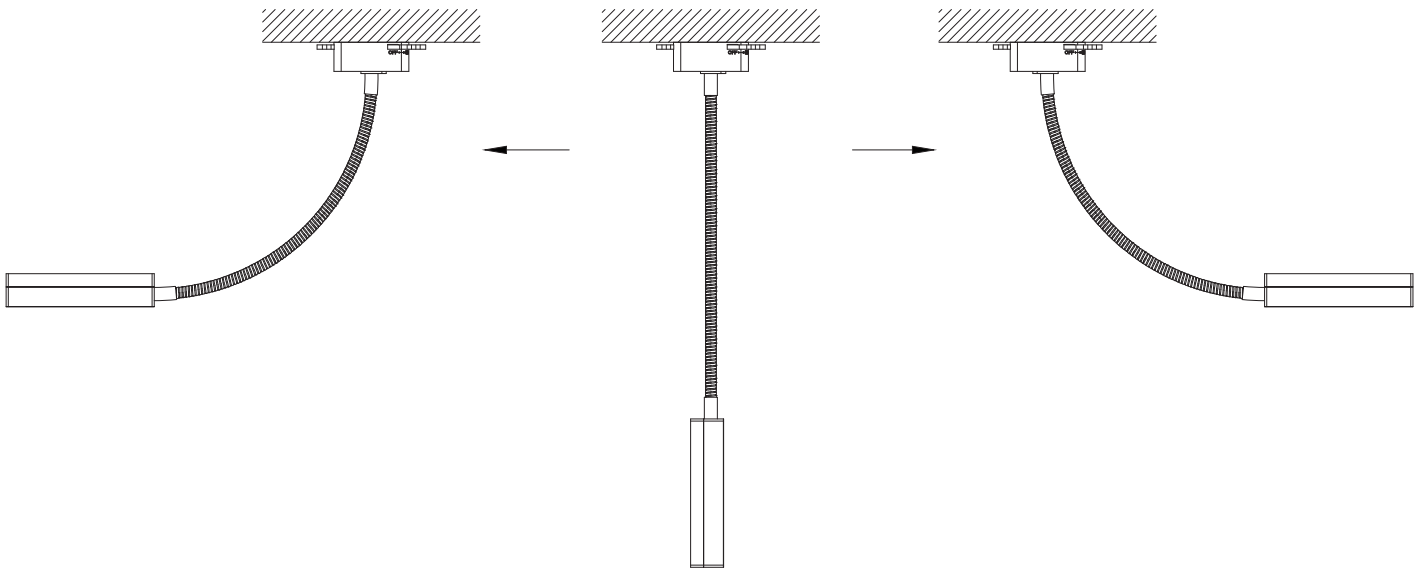

The metal hose can be bent at will to adjust the lighting angle of the lamp

APPLICATION PICTURE



PACKAGING

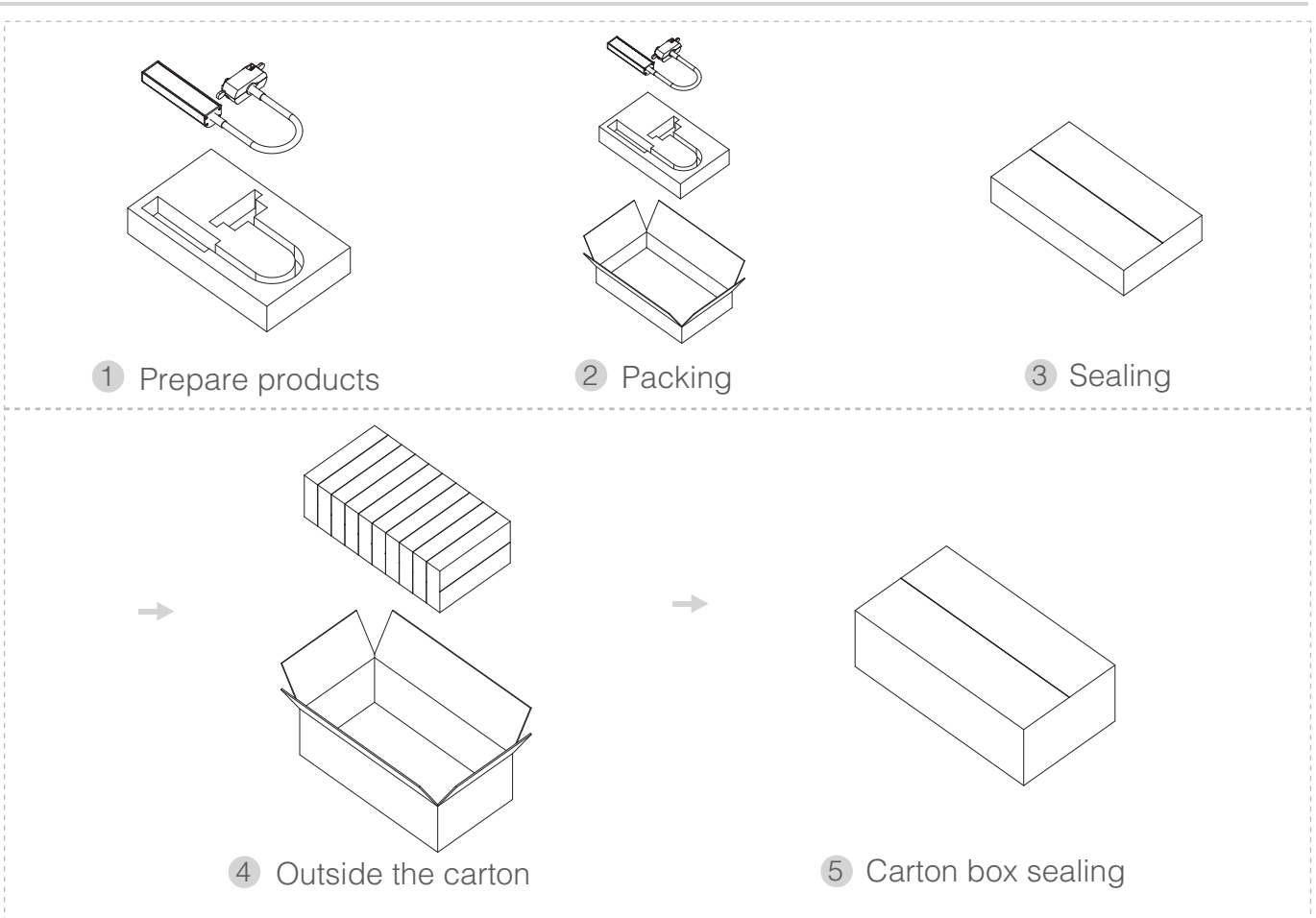

	Model	Inner box	Carton box	QTY/Carton
01	HL-G3035L-A-D01	L316*W186*H60mm	L620*W336*H206mm	10PCS
02	HL-G3035L-B-D01			

NOTICES

- The power supply must be turned off before installation.
- Make sure the product is mounted under the surface of the object to be installed, and finally turn on the power to light up.
- This product is for indoor use only.
- This product is warranted for 3 years and problems occur within 3 years (except for human factors and accidental factors), free maintenance.
- The product is not responsible for damage caused by accidental factors or improper use.

H E L I A N

**Shenzhen
Helian
Electronics Co.,Ltd**

Shenzhen Helian Electronics Co.,Ltd



3F, Tonggao building 2, Sanlian industrial area, Songbai Rd, Shiyan Town, Bao'an District, Shenzhen, Guangdong, China



OUR EMAIL

admin@hllcd.com



OUR PHONE

(86)-755-27606785



OUR WEBSITE

www.hllcd.com