



---

# Model: HL-B3035L-D01



## SIZE

---

Unit: mm    Color: 

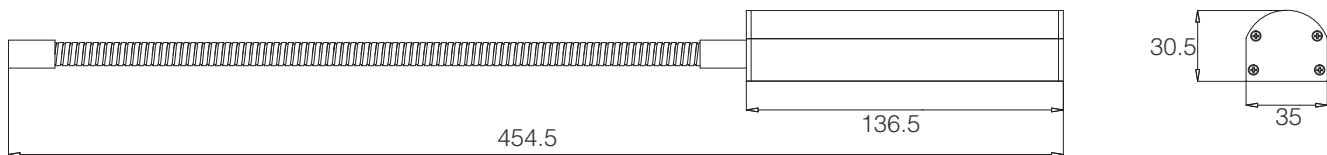

## Feature

---

- The integrated design of hose, lamp body and ceiling plate is adopted, and the appearance design is simple and compact;
- Using SMD LED light source, low power consumption, long life, good heat dissipation performance, energy saving and environmental protection;
- Using PC material cover , high lighting transmittance, strong weather resistance, high temperature resistance, corrosion resistance, and strong impact resistance;
- Optical prism design, anti-glare value UGR<19, soft and comfortable light, protect eyes;
- The main material of the lamp is 6063-T5 aluminum, which has good heat dissipation performance, long service life and is more environmentally friendly;
- The luminous angle of the lamp can be adjusted freely through the hose;

## Accessories

---



Ceiling plate



Clip

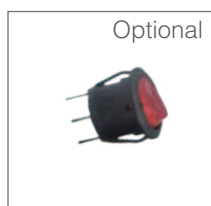

Switch

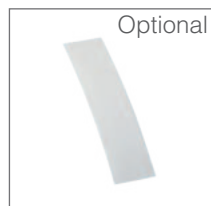

Opal prism diffuser

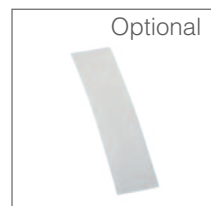

Semi-clear prism diffuser



Clear prism diffuser

## PARAMETERS

Model	HL-B3035L-D01		
Cover	Opal prism diffuser	Semi-clear prism diffuser	Clear prism diffuser
Nominal Power	5W		
LM	425lm	450lm	450lm
Length(L*W*H)	454*35*30.5mm		
Dimming	NO		
Rated Voltage	DC12-24V		
CRI	>70		
Beam Angle	110°		
CCT	2700-6500k		
Warranty	3 years		
N.W	0.26KG		
Working Temperature	-20~+50℃		

## INSTRUCTIONS

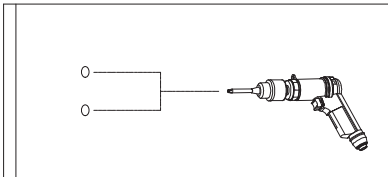

Step 1: Use an electric drill to drill a hole at a suitable position on a wooden board or cement wall.

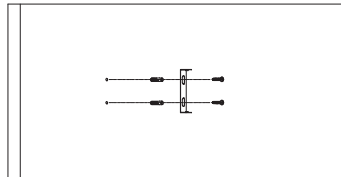

Step 2: Fix the rubber plug, hanging board, and screw on the hole in the wooden board or cement wall in turn.

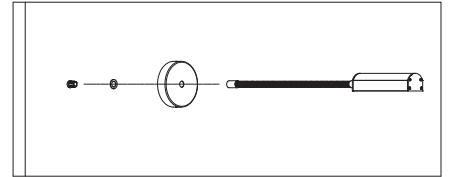

Step 3: Connect and fix the masonry screw, gasket, ceiling plate and hose lamps in sequence.

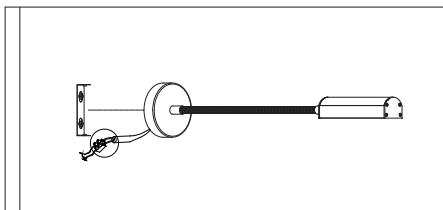

Step 4: Fix the light fixture on the hanging board with screws.

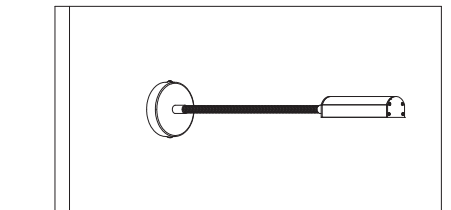
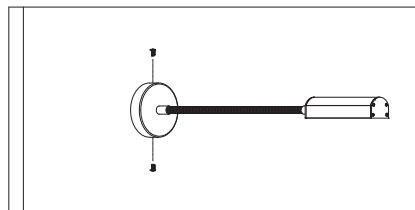

Step 5: Installation is complete.

## ROTATION DIAGRAM

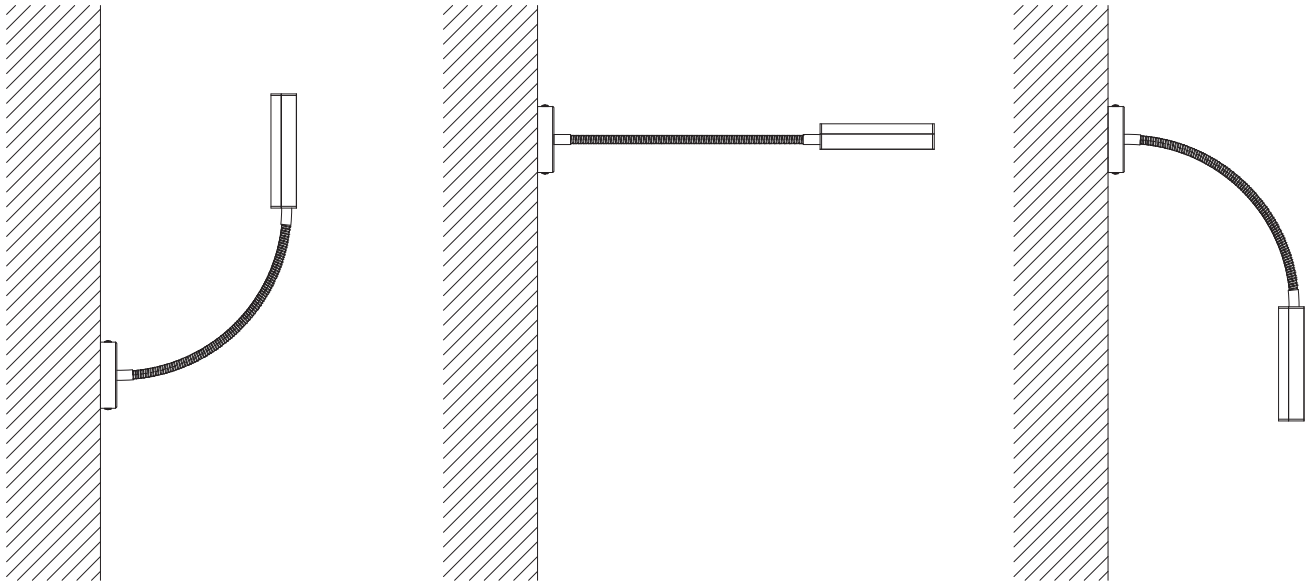

## APPLICATION PICTURE



# PACKAGING

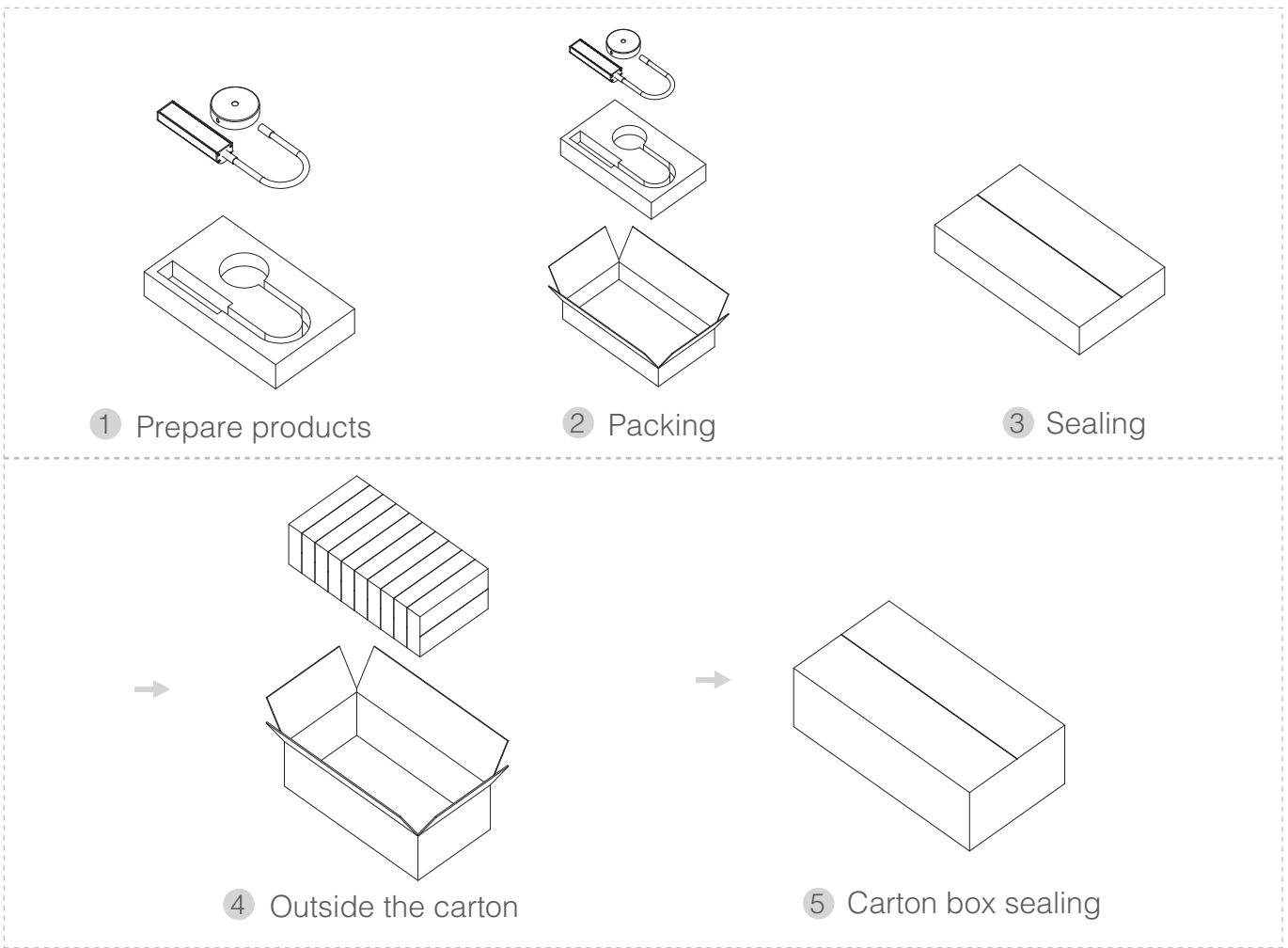

	Model	Inner box	Carton box	QTY/Carton
01	HL-B3035L-D01	316*186*60mm	620*336*206mm	10PCS

## NOTICES

- The power supply must be turned off before installation.
- Make sure the product is mounted under the surface of the object to be installed, and finally turn on the power to light up.
- This product is for indoor use only.
- This product is warranted for 3 years and problems occur within 3 years (except for human factors and accidental factors), free maintenance.
- The product is not responsible for damage caused by accidental factors or improper use.

H E L I A N

**Shenzhen  
Helian  
Electronics Co.,Ltd**

**Shenzhen Helian Electronics Co.,Ltd**



3F, Tonggao building 2, Sanlian industrial area, Songbai Rd, Shiyan Town, Bao'an District, Shenzhen, Guangdong, China



**OUR EMAIL**

admin@hllcd.com



**OUR PHONE**

(86)-755-27606785



**OUR WEBSITE**

www.hllcd.com