

Color 

Unit: mm

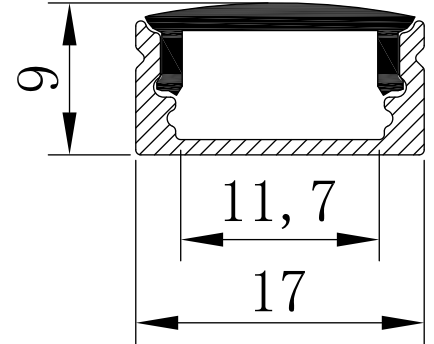

Features:

1. High efficiency, energy saving, long life, environmental protection.
2. Sharp lines, simple appearance.
3. DC12V or DC24V power supply, safe and reliable.
4. Anodized aluminum profile with good heat sink.
5. For wardrobe/Bookcase/Bars/Counters and other cabinet application.
6. Light touch control switch and stepless dimming, fun and practical.

Parameters:



Model	Length	Color	Dimming	Vi/ac	Vo/dc	Io/A	Power	Lm	CRI	CCT	Warranty	Working Temperature
HL-1709T03	0.30 m		YES	100-240v	12v	0.25	3w	150	>80	2700-6500K	1 years	-20~+50°C
HL-1709T06	0.60 m		YES	100-240v	12v	0.50	6w	300	>80	2700-6500K	1 years	-20~+50°C

The Light Map:

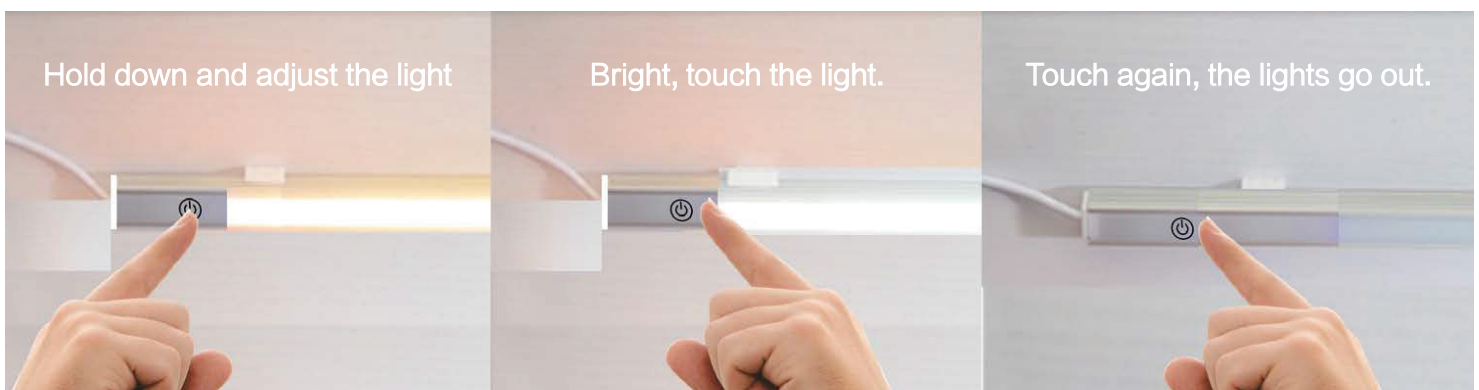

The Light Map:

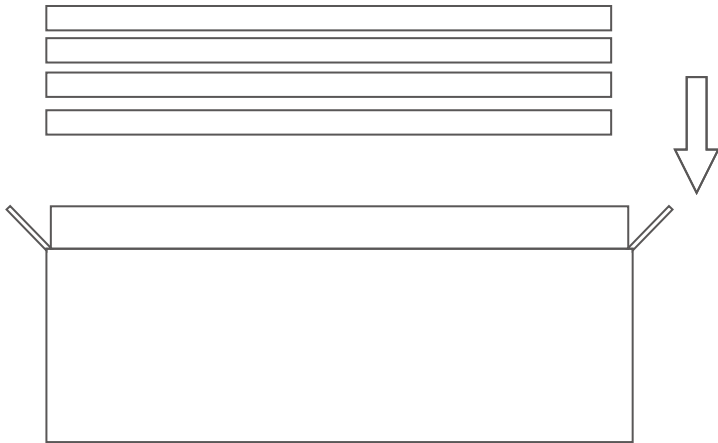

Model	Box size	Carton size	QTY/Box	QTY/Carton
HL-1709L03	85*55*420 mm	450*440*570 mm	1 PCS	50 PCS
HL-1709L06	85*55*720 mm	450*460*740 mm	1 PCS	40 PCS

Installation:

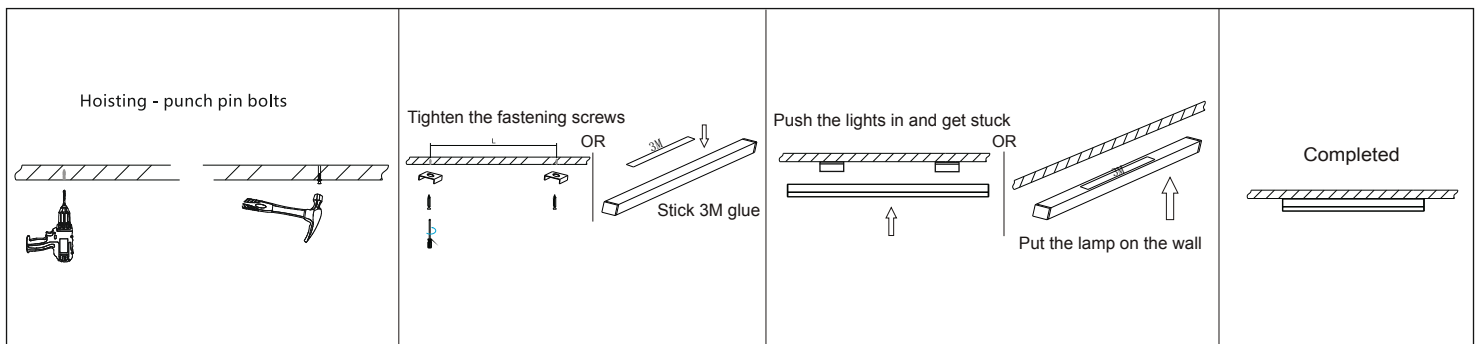

Notice:

1. Ensure installed surface tidy, clean and dry.
2. Please use qualified SMPS with short circuit protection, overload protection and S.O.P. certificate.
3. During the process of installing or maintaining for lamps shall not switch on the power, Only after ensured correct wiring connection and fixed installation can switch on the power. Working voltage must conform to the voltage of production.
4. Just for indoor using and cannot be installed in the inflammable and explosive environment. Light body should be well ventilated.

Application:



Shenzhen Helian Electronics Co., Ltd

Address: 3F, Tonggao building 2, Sanlian industrial area, Songbai Rd, Shiyan Town, Bao' an District, Shenzhen, Guangdong, China

Tel: +86-755-27606785

Fax: 86-755-27607521

Websites: www.hllled.cn

Email: hllled@hllled.cn